

GENERATOR WINDING INSULATION

- TEST AND VERIFY FOR QUALITY STATOR WINDINGS

Jack Heaton
Andritz Hydro



Philosophy of Insulation

- Insulation quality and reliability needs to be based on extensive experience with older systems
 - It is not a “calculated” technology
 - Relies on comparative test results
- New insulation system evaluation is based on multiple test value comparisons
 - Resin chemistry cure
 - Resin chemistry aging
 - Resin dielectric data
 - Mica tape compatibility
 - Mica tape shelf life
 - Winding diagnostics
 - Winding aging (temperature and voltage)
 - Partial Discharge resistance

Hi Potential Testing

High Voltage is used to test the insulation system over the life of a generator

- Testing during manufacturing
- Endurance type qualification testing
- Testing during installation of winding
- Testing during maintenance or after repair

The condition of the insulation is determined during and after applying voltage stress

Many feel that one should never shy away from an AC hi pot and that if failure does occur during this testing, that the coil or bar was near enough to the end of life or damaged sufficiently to warrant replacement.

Hi Potential Testing

- Hi Pot testing is a history test and there is no guarantee that because it passed first test that it will pass the second test.
- Hi Pot test by itself cannot assure that the winding is of high quality
- The amount of “life” sacrificed by hi pot testing for 1 minute is insignificant in comparison to the information that additional testing can provide regarding insulation condition
- AC voltage divides among insulations as the inverse of the dielectric constants of the materials and air
- DC voltage divides resistively. In the slot the difference in stress distribution does not concentrate stress through the insulation in the same manner as AC and is less stressful
- The differences in systems can be realized in an area such as the endwinding where large air spaces are critical especially when there could be dirt or moisture in the air which affects resistivity.
- Arcing and sparking in the endwinding are common on DC testing which would not be present during AC testing and this sparking can become pronounced enough in poor conditions to cause burning or other damage to the endwinding components
- Hi Pot on fully cured samples is a prudent test for quality and is a good test to weed out gross mistakes such as bumping or dropping the winding during manufacturing or installation

Stator Insulation Tests



Caution when doing HV test.

Read:

IEEE Std. 510: IEEE Recommended Practices for Safety in High-Voltage and High-Power Testing.

Test Purposes

- **Testing**
 - **Material evaluations and characteristics**
 - **Development modeling of insulation systems**
 - **Complete system evaluation (full coils and bars)**
 - **Quality Assurance**
 - **During manufacturing process**
 - **During Installation/Assembly**
- **Types of tests**
 - **Electrical**
 - **Thermal, Mechanical & Physical**
 - **Chemical**

Testing Thermal, Mechanical & Physical Properties

- **Thermal**
 - Thermal Conductivity
- **Mechanical**
 - Strain Capability
 - Modulus of Elasticity
- **Physical**
 - Manufacturing Dimension/Shape Checks
 - Visual inspection
 - Insulation Dissection
- **Thermal Cycling – IEEE 1310**

Electrical Tests

- **Dielectric properties**
 - Short Time Breakdown Strength
 - Dissipation Factor ($\tan \delta$) and Tip-Up ($\Delta \tan \delta$) at room temp.
 - Dissipation Factor ($\tan \delta$) at elevated temp.
 - Dielectric Constant (Relative Permittivity)
 - Resistivity and Polarization Index
- **Insulation System Test**
 - Voltage Endurance – IEEE 1043
- **Other tests**
 - Partial discharge detection, measurement, and location determination

Tests during the Manufacturing process

QA tests are conducted as follows:

- **Strand shorts**
- **Dimensional**
- **Surface resistivity of slot armor**
- **Dark Corona**
- **Impulse turn test (only coils)**
- **HiPot (shop test level is higher than that on the wound machine)**
- **DF and Tip-up**

After Manufacturing Approval Tests

- **Before installation, several tests can be carried out in order to approve or verify the quality of the insulation system.**

These tests include, but not limited to:

- **Polarization Index (PI)**
- **Dissipation Factor (DF) and Tip-up**
- **Voltage Endurance (VE)**
- **Thermal Cycling (TC)**
- **Partial Discharge (PD)**
- **Puncture / Breakdown**

Polarization Index (PI)

Definition	<p>PI is the ratio of the Insulation Resistance at two different instances after application of a high DC voltage, usually IR_{10min}/IR_{1min}</p> <p>The insulation resistance test history of a given machine, measured at uniform conditions so far as the controllable variables are concerned, is recognized as a useful way of trending some aspects of the insulation condition over years.</p> <p>Estimation of the suitability of a machine for the application of appropriate overvoltage tests or for operation may be based on a comparison of present and previous P.I. and/or IR1 values.</p>
Reference	IEEE Std. 43-2000 (Reaffirmed 2006)
Equipment	Insulation Tester Megger
Test Procedure	Application of a DC voltage (e.g. 5kV for 5-12kV machines) and reading the resistance and different instants of time
Influencing Factors	Humidity, surface contamination, temperature, voltage applied
Suitable Result	When the IR_{1min} is higher than 5000 M Ω , the PI may or may not be an indication of the insulation condition and is therefore not recommended as an assessment tool. For details see IEEE Std. 43.

DF and Tip-up

Definition	<p>Measurement of Dissipation Factor versus various voltages. The DF tip-up is defined as the difference in the DF measured at two voltages.</p> <p>Ionization of gaseous voids (PD) in the insulation structure causes an increase in DF with voltage increase as the critical voltage gradient is exceeded. High DF or DF increase due to increase of voltage (high Tip-up) is the sign of PD activities inside the insulation.</p> <p>The initial value of DF is used to determine the cure state of the insulation system.</p>
Reference	IEEE Std. 286-2000 (Reaffirmed 2006)
Equipment	Bridge (e.g. Tettex) and HV transformer
Test Procedure	HV at different levels is applied and DF alongside with capacitance is measured
Influencing Factors	Besides environmental parameters as Humidity and Temperature, the test is very sensitive to interferences, equipment sensitivities, surface corona, surface contamination and grading quality. Guarding is usually applied.
Suitable Result	<p>Dependent on the insulation system. The the value should usually be consistent with the particular insulation system being measured.</p> <p>Results cannot be regarded as an absolute indication of the condition of the coil insulation, however a change during service life may be the result of deterioration processes.</p> <p>As an example, for Autoclave systems and for a single bar, the values below 1% for DF and Tip-ups virtually null are proffered.</p>

Voltage Endurance (VE)

- VE in essence is a test that quantitatively measures the capability of an insulation system to withstand partial discharge (corona) at operating temperature, which in turn is a measure of the quality of the design of the materials , and of the manufacturing process.
- Partial discharge or df measurements are made during the progress of the voltage endurance test to to detect changes in advance of the electrical breakdown end point.
- Test method to acknowledge the corona inception voltage of the system or establish the relative slope of the voltage endurance curve.
- A flatter VE curve is indicative of a system with better corona resistance.
- Good philosophy is that systems with enhanced corona resistance yield better life provided that the contact to the core is maintained.

Voltage Endurance (VE)

Definition	<p>Measures the life length of the insulation system at high temperature and under high applied electric field</p> <p>The test will evaluate the condition of the production as well as the resistance of the system against internal PD activities, as the main failure syndrome in rotating machine insulation.</p>
Reference	IEEE Std. 1043-1996, IEEE Std. 1553-2002
Equipment	HV transformer, Controllable heaters, DAQ system
Test Procedure	<p>Insulated specimens are heated to a temperature close to working values (e.g. 120°C) and then the predetermined HV is applied. Temperature and voltage are maintained until failure occurs.</p> <p>Several diagnosis tests (e.g. PI, HiPot, PD, DF and tip-up) are carried out prior this test.</p>
Influencing Factors	<p>Care should be taken during installation and handling.</p> <p>Voltage and heat control systems should be robust.</p>
Suitable Result	Depends on the schedule and number of specimens. For details see IEEE Std. 1553, section 5.

Voltage Endurance Test Lab

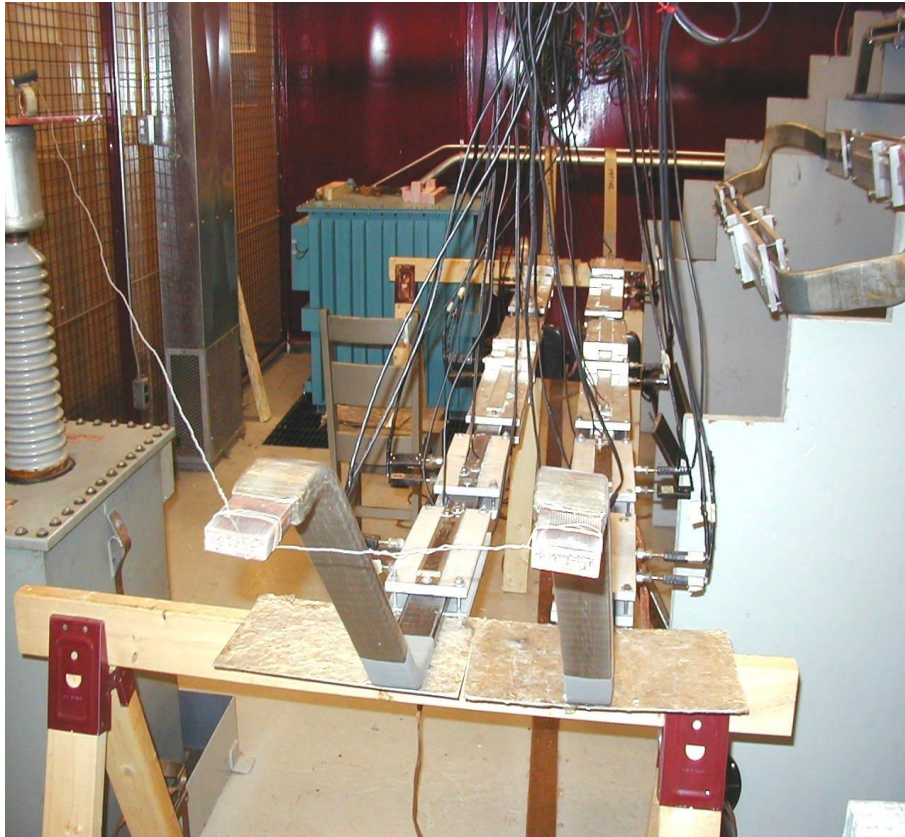

Thermal Cycling

Definition	<p>This test will evaluate the insulation system performance against frequent load variations, and/or numerous start-stop cycles.</p> <p>This conditions lead to variation of insulation temperature and may result in detachment of copper to groundwall (delamination) as well as creation of voids.</p>
Reference	IEEE Std. 1310-1996,
Equipment	High Current Transformer, Controlled Cooler, DAQ system
Test Procedure	<p>Specimens are heated by passing high currents through them to cause a linear rate in temperature increase over a certain time period (e.g. 40 to 130oC during 45min). Then the current will be removed and the test objects will be brought to initial temperature using controlled cooling fans and then the cycle is repeated (e.g. 500 times).</p> <p>Diagnosis tests as PD, DF and tip-up are carried out prior to this test, and at several number of cycles in order to monitor and assess the degradation of the insulation.</p> <p>This test is usually followed by a VE test.</p>
Influencing Factors	<p>Care should be taken during installation and handling.</p> <p>Current and heat control systems should be robust.</p>
Suitable Result	Depending on the insulation system and number of specimens, low values of variation in assessment indexes (such as DF) over cycles are desired.

Thermal Cycling Test



Thermal Cycling Test - IEEE 1310

Built-up of Acceptance Test on Hydro Generator Bars

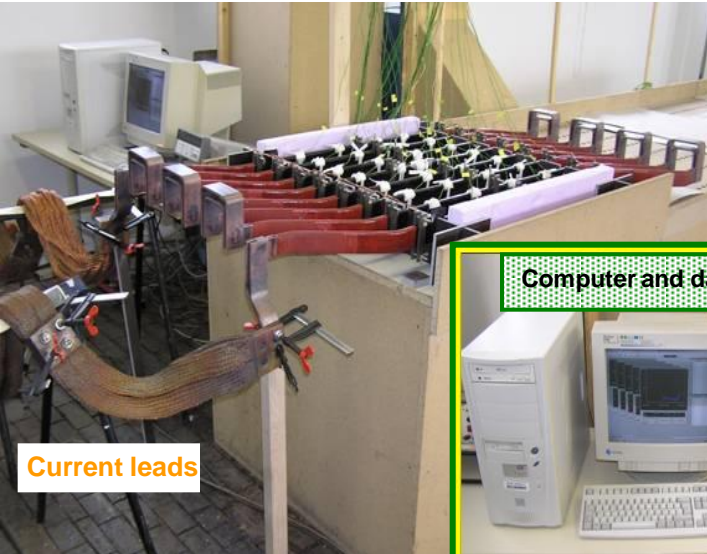

Thermal Cycling Test - IEEE 1310

Arrangement for Acceptance Test on Hydro Generator Bars

(Cycles between 40°C and 155°C – copper temperature)

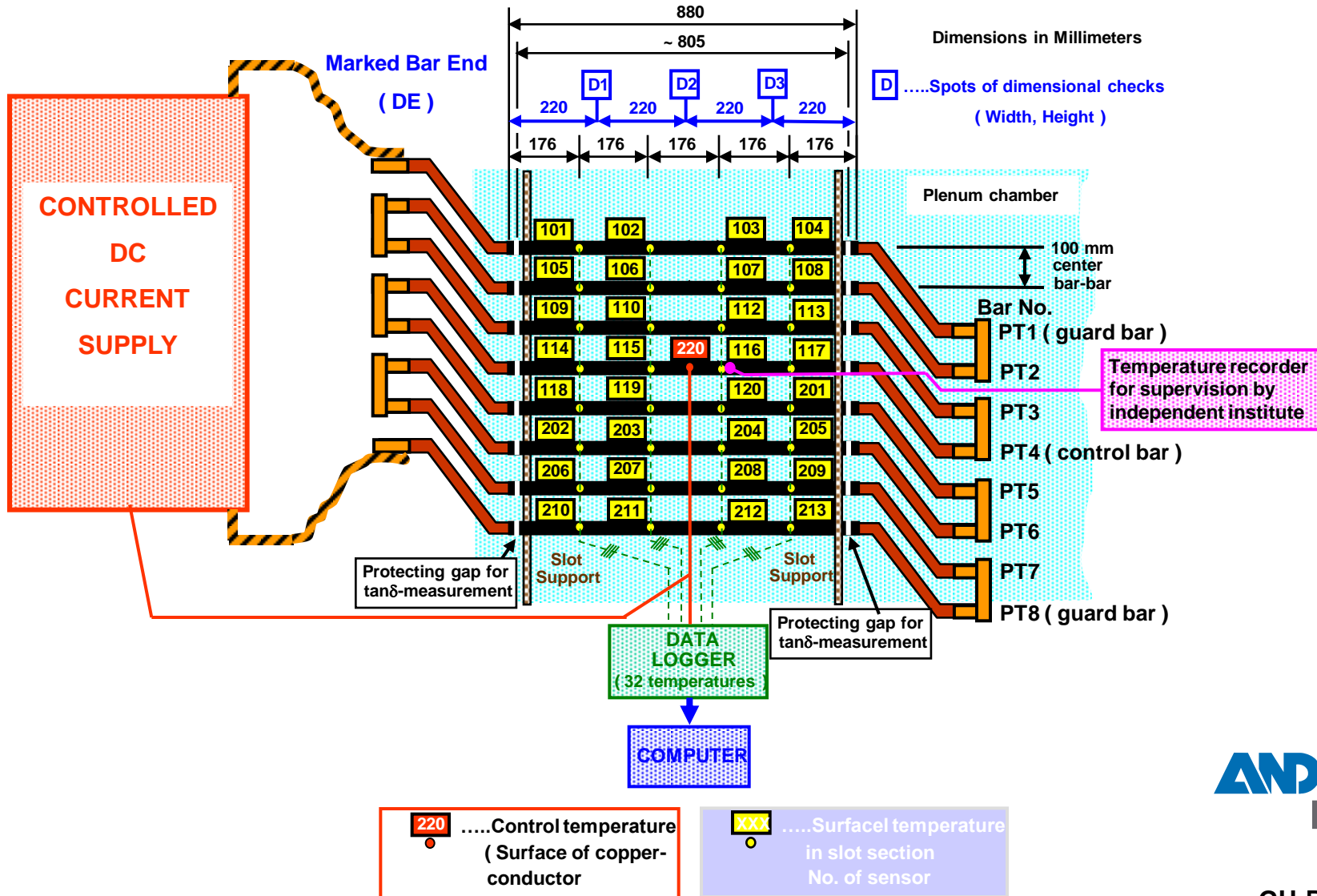

Partial Discharge (PD)

Definition	quantifies the insulation condition by measurement and counting of PD pulses.
Reference	IEEE Std. 1434-2000
Equipment	PD analyzer, Coupler and HV transformer
Test Procedure	Following PDA manual, the PD pulses are measured after application of HV at different levels
Influencing Factors	The results are sensitive to interferences and noises. Sharp edges and corona surfaces should be avoided and adequate clearance should be provided.
Suitable Result	High number of PD pulses (compared to similar specimens using similar insulation systems) as well as drastic increase in results are the sign of degradation.

Mechanical Testing



Tensile Strength

- Compressive Strength
- Fatigue
- Flexure Strength

Insulation Dissection

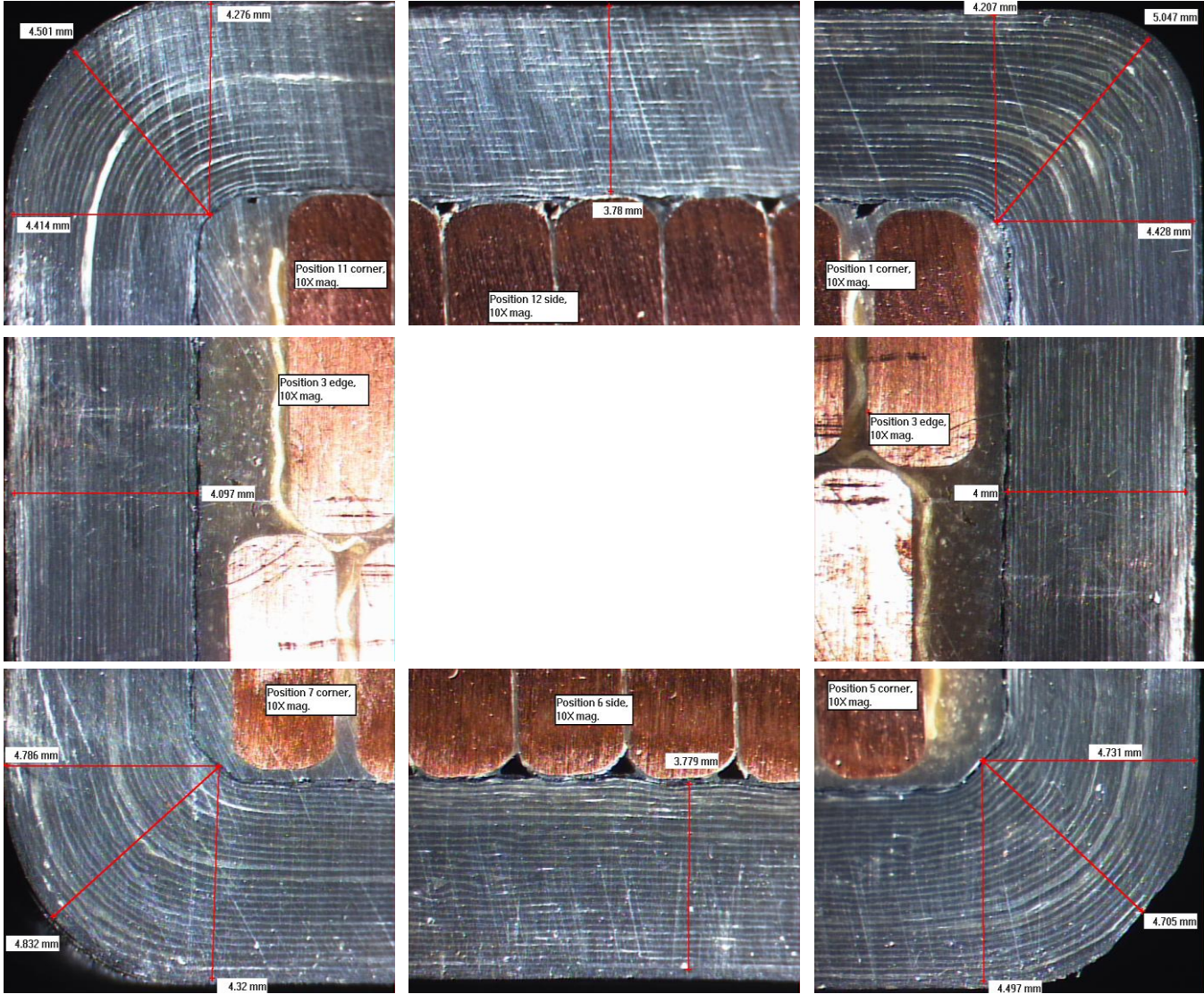

Thermal Cycling Test Capability of Lab

Heating currents up to 7000 Amperes

Chamber length maximum approx. 5800 mm

Second smaller thermal cycling set has currents up to 3000 Amperes.

Voltage Endurance (VE) test equipment:

transformer 125 kV:

VE tests at room temperature

VE test in chamber (max. length 10 meters, $\leq 155^{\circ}\text{C}$)

VE test with controlled heating plates (IEEE 1043)

transformer 50 kV, 200 kVA (photo " 50 kV-A "):

transformer 50 kV, 125 kVA (photo " 50 kV-B"):

transformer 20 kV, 125 kVA:

Lab Test Equipment List

Mechanical Test

Tensile Test Machine ZWICK 1484, 200 kN, NC

Tensile Test Machine OLSEN, 600 kN, manual control

Notch Impact Test Machine, max. 300 J, Temp. Range -60°C..Ambient

Hardness Test Device (VICKERS)

Reflected Light Microscope REICHERT

Stereo Microscope REICHERT 5-135x

Coating Thickness Measuring Device 0..3000 microns

Shear Test Device for Coatings EIC TWIST-O-METER

Electrical and Magnetic Testing

Epstein Test Device BROCKHAUS MPG 100 D AC (for AC magnetisation tests)

Magnetization Test Device DC, B25-B300 (for DC magnetisation tests)

Conductivity Test Device SIGMATEST

Insulation

PD - measurement systems (VATECH-QC, IRIS, ICM), Coronascope Chamber or platen VE

7000 amp TC set

20 50 125 kV test supplies

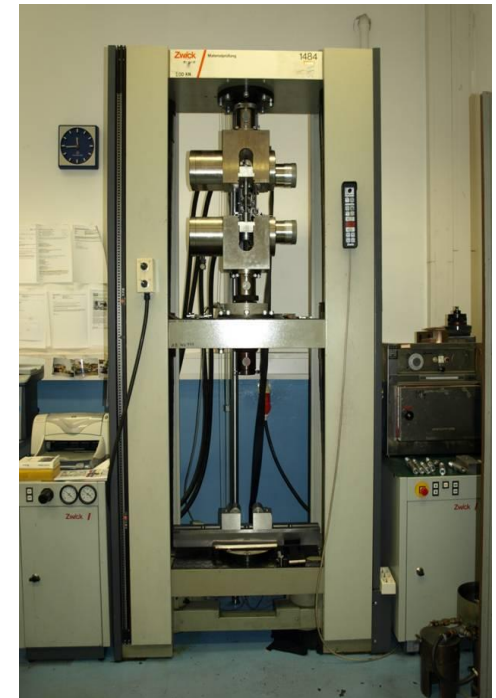

ANDRITZ
Hydro